

Technical Overview and Benefits of the IEC 61850 Standard for Substation Automation

Ralph Mackiewicz
SISCO, Inc.
Sterling Heights, MI
USA

Abstract-- Legacy substation automation protocols and architectures typically provided basic functionality for power system automation and were designed to accommodate the technical limitations of the networking technology available for implementation. There has recently been a vast improvement in networking technology that has changed dramatically what is now feasible for power system automation in the substation. Technologies such as switched Ethernet, TCP/IP, high-speed wide area networks, and high-performance low-cost computers are providing capabilities that could barely be imagined when most legacy substation automation protocols were designed. IEC61850 is an important new international standard for substation automation that will have a very significant impact on how electric power systems are designed and built for many years to come. IEC61850 is a part of the International Electrotechnical Commission's (IEC) Technical Committee 57 (TC57) architecture for electric power systems. The model-driven approach of the TC57 standards, including IEC61850, is an innovative approach that requires a new way of thinking about substation automation that will result in very significant improvements in both costs and performance of electric power systems.

I. COMMUNICATION SYSTEM NEEDS

Communication has always played a critical role in the real-time operation of the power system. In the beginning, the telephone was used to communicate line loadings back to the control center as well as to dispatch operators to perform switching operations at substations. Telephone-switching based remote control units were available as early as the 1930's and were able to provide status and control for a few points. As digital communications became a viable option in the 1960's, data acquisition systems (DAS) were installed to automatically collect measurement data from the substations. Since bandwidth was limited, DAS communication protocols were optimized to operate over low-bandwidth communication channels. The "cost" of this optimization was the time it took to configure, map, and document the location of the various data bits received by the protocol.

As we move into the digital age, literally thousands of analog and digital data points are available in a single Intelligent Electronic Device (IED) and communication bandwidth is no longer a limiting factor. Substation to master communication data paths operating at 64,000 bits per second are now commonplace with an obvious migration path to

much higher rates. With this migration in technology, the "cost" component of a data acquisition system has now become the configuration and documentation component. Consequently, a key component of a communication system is the ability to describe themselves from both a data and services (communication functions that an IED performs) perspective. Other "key" requirements include:

- High-speed IED to IED communication
- Networkable throughout the utility enterprise
- High-availability
- Guaranteed delivery times
- Standards based
- Multi-vendor interoperability
- Support for Voltage and Current samples data
- Support for File Transfer
- Auto-configurable / configuration support
- Support for security

Given these requirements, work on a "next generation" communication architecture began with the development of the Utility Communication Architecture (UCA) in 1988. The result of this work was a profile of "recommended" protocols for the various layers of the International Standards Organization (ISO) Open System Interconnect (OSI) communication system model. This architecture resulted in the definition of a "profile" of protocols, data models, and abstract service definitions that became known as UCA. The concepts and fundamental work done in UCA became the foundation for the work done in the IEC Technical Committee Number 57 (TC57) Working Group 10 (WG10) which resulted in the International Standard – IEC 61850 – Communication Networks and Systems in Substations.

II. SCOPE AND OUTLINE OF IEC 61850

The stated scope of IEC 61850 was communications within the substation. The document defines the various aspects of the substation communication network in 10 major sections as shown in Table 1 below.

TABLE I
STRUCTURE OF THE IEC 61850 STANDARD

Part #	Title
1	Introduction and Overview
2	Glossary of terms
3	General Requirements
4	System and Project Management
5	Communication Requirements for Functions and Device Models
6	Configuration Description Language for Communication in Electrical Substations Related to IEDs
7	Basic Communication Structure for Substation and Feeder Equipment
7.1	- Principles and Models
7.2	- Abstract Communication Service Interface (ACSI)
7.3	- Common Data Classes (CDC)
7.4	- Compatible logical node classes and data classes
8	Specific Communication Service Mapping (SCSM)
8.1	- Mappings to MMS(ISO/IEC 9506 – Part 1 and Part 2) and to ISO/IEC 8802-3
9	Specific Communication Service Mapping (SCSM)
9.1	- Sampled Values over Serial Unidirectional Multidrop Point-to-Point Link
9.2	- Sampled Values over ISO/IEC 8802-3
10	Conformance Testing

Parts 3, 4, and 5 of the standard start by identifying the general and specific functional requirements for communications in a substation (key requirements stated above). These requirements are then used as forcing functions to aid in the identification of the services and data models needed, application protocol required, and the underlying transport, network, data link, and physical layers that will meet the overall requirements.

The major architectural construct that 61850 adopts is that of “abstracting” the definition of the data items and the services, that is, creating data items/objects and services that are independent of any underlying protocols. The abstract definitions then allow “mapping” of the data objects and services to any other protocol that can meet the data and service requirements. The definition of the abstract services is found in part 7.2 of the standard and the abstraction of the data objects (referred to as Logical Nodes) is found in part 7.4. In as much as many of the data objects are made up of common pieces (such as Status, Control, Measurement, Substitution), the concept of “Common Data Classes” or “CDC” was developed which defined common building blocks for creating the larger data objects. The CDC elements are defined in part 7.3.

Given the data and services abstract definitions, the final step was one of “mapping” the abstract services into an actual protocol. Section 8.1 defines the mapping of the abstract data

object and services onto the Manufacturing Messaging Specification – MMS and sections 9.1 and 9.2 define the mapping of the Sample Measured Values (unidirectional point-to-point and bi-directional multipoint accordingly) onto an Ethernet data frame. The 9.2 document defines what has become known as the Process Bus.

From a system perspective, there is a significant amount of configuration that is required in order to put all the pieces together and have them work. In order to facilitate this process and to eliminate much of the human error component, an XML based Substation Configuration Language (SCL) was defined in part 6. It allows the formal description of the relations between the substation automation system and the substation (switchyard). At the application level, the switchyard topology itself and the relation of the switchyard structure to the SAS functions (logical nodes) configured on the IEDs can be described. Each device must provide an SCL file that describes the configuration of itself.

Although the scope of 61850 was originally focused “inside” the substation, discussions are underway to look at defining 61850 for the Substation to Master communication protocol (already in service in several installations). In addition, applications are in service that uses various components of 61850 for wide area substation-to-substation communication.

Finally, part 10 of the document defines a testing methodology in order to determine “conformance” with the numerous protocol definitions and constraints defined in the document.

The rest of this paper goes into some focused details of the various parts of the IEC 61850 standard.

III. MODELING APPROACH

Legacy protocols have typically defined how bytes are transmitted on the wire. However, they did not specify how data should be organized in devices in terms of the application. This approach requires power system engineers to manually configure objects and map them to power system variables and low-level register numbers, index numbers, I/O modules, etc. IEC 61850 is unique. In addition to the specification of the protocol elements (how bytes are transmitted on the wire), IEC 61850 provides a comprehensive model for how power system devices should organize data in a manner that is consistent across all types and brands of devices. This eliminates much of the tedious non-power system configuration effort because the devices can configure themselves. For instance, if you put a CT/VT input into an IEC 61850 relay, the relay can detect this module and automatically assign it to a measurement unit without user interaction. Some devices use an SCL file to configure the objects and the engineer need only import the SCL file into the device to configure it. Then, the IEC 61850 client application can extract the object definitions from the device

over the network. The result is a very large savings in the cost and effort to configure an IEC 61850 device.

The IEC 61850 device model begins with a physical device. A physical device is the device that connects to the network. The physical device is typically defined by its network address. Within each physical device, there may be one or more logical devices. The IEC 61850 logical device model allows a single physical device to act as a proxy or gateway for multiple devices thus providing a standard representation of a data concentrator.

XCBR class				
Attribute Name	Attr. Type	Explanation	T	M/O
LNName		Shall be inherited from Logical-Node Class (see IEC 61850-7-2)		
Data				
Common Logical Node Information				
LN shall inherit all Mandatory Data from Common Logical Node Class				
Loc	SPS	Local operation (local means without substation automation communication, hardwired direct control)		M
EEHealth	INS	External equipment health		O
EEName	DPL	External equipment name plate		O
OpCnt	INS	Operation counter		M
Controls				
Pos	DPC	Switch position		M
BlkOpn	SPC	Block opening		M
BlkCls	SPC	Block closing		M
ChaMotEna	SPC	Charger motor enabled		O
Metered Values				
SumSwARs	BCR	Sum of Switched Amperes, resettable		O
Status Information				
CBOpCap	INS	Circuit breaker operating capability		M
POWCap	INS	Point On Wave switching capability		O
MaxOpCap	INS	Circuit breaker operating capability when fully charged		O

↑ Data Name
 ↑ Common Data Class
 ↑ Mandatory/Optional

Fig. 1. Anatomy of Circuit Breaker (XCBR) Logical Node in IEC 61850-7-4

Each logical device contains one or more logical nodes. A logical node (see figure 1) is a named grouping of data and associated services that is logically related to some power system function. There are logical nodes for automatic control the names of which all begin with the letter “A”. There are logical nodes for metering and measurement the names of which all begin with the letter “M”. Likewise there are logical nodes for Supervisory Control (C), Generic Functions (G), Interfacing/Archiving (I), System logical nodes (L), Protection (P), Protection Related (R), Sensors (S), Instrument Transformers (T), Switchgear (X), Power Transformers (Y), and Other Equipment (Z). Each logical node has an LN-Instance-ID as a suffix to the logical node name. For instance, suppose there were two measurement inputs in a device to measure two 3-phase feeders. The standard name of the logical node for a Measurement Unit for 3-phase power is MMXU. To delineate between the measurements for these 2 feeders the IEC 61850 logical node names of MMXU1 and MMXU2 would be used. Each logical node may also use an optional application specific LN-prefix to provide further identification of the purpose of a logical node.

Each logical node contains one or more elements of Data. Each element of data has a unique name. These Data Names are determined by the standard and are functionally related to the power system purpose. For instance, a circuit breaker is modeled as an XCBR logical node. It contains a variety of Data including Loc for determining if operation is remote or local, OpCnt for an operations count, Pos for the position, BlkOpn block breaker open commands, BlkCls block breaker

close commands, and CBOpCap for the circuit breaker operating capability.

Each element of data within the logical node conforms to the specification of a common data class (CDC) per IEC 61850-7-3. Each CDC describes the type and structure of the data within the logical node. For instance, there are CDCs for status information, measured information, controllable status information, controllable analog set point information, status settings, and analog settings. Each CDC has a defined name and a set of CDC attributes each with a defined name, defined type, and specific purpose. Each individual attribute of a CDC belongs to a set of functional constraints (FC) that groups the attributes into categories. For instance, in the Single Point Status (SPS) CDC described in Figure 2, there are functional constraints for status (ST) attributes, substituted value (SV) attributes, description (DC) attributes, and extended definition (EX) attributes. In this example the status attributes of the SPS class consists of a status value (stVal), a quality flag (q), and a time stamp (t).

SPS class					
Attribute Name	Attribute Type	FC	TrgOp	Value/Value Range	M/O/C
DataName	Inherited from Data Class (see IEC 61850-7-2)				
DataAttribute					
<i>status</i>					
stVal	BOOLEAN	ST	dchg	TRUE FALSE	M
q	Quality	ST	qchg		M
t	TimeStamp	ST			M
<i>substitution</i>					
subEna	BOOLEAN	SV			PICS_SUBST
subVal	BOOLEAN	SV		TRUE FALSE	PICS_SUBST
subQ	Quality	SV			PICS_SUBST
subID	VISIBLE STRING64	SV			PICS_SUBST
<i>configuration, description and extension</i>					
d	VISIBLE STRING255	DC		Text	O
dU	UNICODE STRING255	DC			O
cdcNs	VISIBLE STRING255	EX			AC_DLNDA_M
cdcName	VISIBLE STRING255	EX			AC_DLNDA_M
dataNs	VISIBLE STRING255	EX			AC_DLN_M

↑ Functional Constraint
 ↑ Mandatory/Optional

Fig. 2. Anatomy of the Single Point Status (SPS) Common Data Class in IEC 61850-7-3

The IEC 61850 model of a device is a virtualized model that begins with an abstract view of the device and its objects and is defined in IEC 61850 part 7. Then, this abstract model is mapped to a specific protocol stack in section IEC 61850-8-1 based on MMS (ISO9506), TCP/IP, and Ethernet. In the process of mapping the IEC 61850 objects to MMS, IEC 61850-8-1 specifies a method of transforming the model information into a named MMS variable object that results in a unique and unambiguous reference for each element of data in the model. For instance, suppose that you have a logical device named “Relay1” consisting of a single circuit breaker logical node XCBR1 for which you want to determine if the breaker is in the remote or local mode of operation. To determine this you would read the object shown in figure 3.

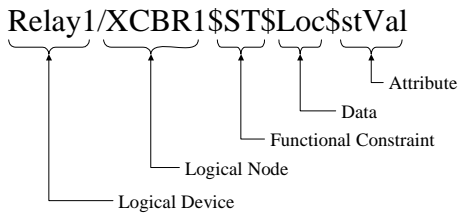

Fig. 3. Anatomy of an IEC 61850-8-1 Object Name

IV. MAPPING TO REAL PROTOCOLS

The abstract data and object models of IEC 61850 define a standardized method of describing power system devices that enables all IEDs to present data using identical structures that are directly related to their power system function. The Abstract Communication Service Interface (ACSI) models of IEC 61850 define a set of services and the responses to those services that enables all IEDs to behave in an identical manner from the network behavior perspective. While the abstract model is critical to achieving this level of interoperability, these models need to be operated over a real set of protocols that are practical to implement and that can operate within the computing environments commonly found in the power industry. IEC 61850-8-1 maps the abstract objects and services to the Manufacturing Message Specification (MMS) protocols of ISO9506. Why was a protocol originally designed for manufacturing used? Because MMS is the only public (ISO standard) protocol that has a proven implementation track record that can easily support the complex naming and service models of IEC 61850. While you can theoretically map IEC 61850 to any protocol, this mapping can get very complex and cumbersome when trying to map IEC 61850 objects and services to a protocol that only provides read/write/report services for simple variables that are accessed by register numbers or index numbers. This was the reason that MMS was chosen for UCA in 1991 and is the reason that it was kept for IEC 61850. MMS is a very good choice because it supports complex named objects and a rich set of flexible services that supports the mapping to IEC 61850 in a straightforward manner.

The mapping of IEC 61850 object and service models to MMS is based on a service mapping where a specific MMS service/services are chosen as the means to implement the various services of ACSI. For instance, the control model of ACSI is mapped to MMS read and write services. Then the various object models of IEC 61850 are mapped to specific MMS objects. For instance, the IEC 61850 logical device object is mapped to an MMS domain. Table 2 below summarizes the mapping of IEC 61850 objects and Table 3 the ACSI mapping to MMS.

TABLE II
IEC 61850 TO MMS OBJECT MAPPING

IEC 61850 Objects	MMS Object
SERVER class	Virtual Manufacturing Device (VMD)
LOGICAL DEVICE class	Domain
LOGICAL NODE class	Named Variable
DATA class	Named Variable
DATA-SET class	Named Variable List
SETTING-GROUP-CONTROL-BLOCK class	Named Variable
REPORT-CONTROL-BLOCK class	Named Variable
LOG class	Journal
LOG-CONTROL-BLOCK class	Named Variable
GOOSE-CONTROL-BLOCK class	Named Variable
GSSE-CONTROL-BLOCK class	Named Variable
CONTROL class	Named Variable
Files	Files

TABLE III
IEC 61850 PARTIAL SERVICE MAPPING

IEC 61850 Services	MMS Services
LogicalDeviceDirectory	GetNameList
GetDataValues	Read
SetDataValues	Write
GetDataDirectory	GetNameList
GetDataDefinition	GetVariableAccessAttributes
GetDataSetValues	Read
SetDataSetValues	Write
CreateDataSet	CreateNamedVariableList
DeleteDataSet	DeleteNamedVariableList
GetDataSetDirectory	GetNameList
Report (Buffered and Unbuffered)	InformationReport
GetBRCBValues/GetURCBValues	Read
SetBRCBValues/SetURCBValues	Write
GetLCBValues	Read
SetLCBValues	Write
QueryLogByTime	ReadJournal
QueryLogAfter	ReadJournal
GetLogStatusValues	GetJournalStatus
Select	Read/Write
SelectWithValue	Read/Write
Cancel	Write
Operate	Write
Command-Termination	Write
TimeActivated-Operate	Write
GetFile	FileOpen/FileRead/FileClose
SetFile	ObtainFile
DeleteFile	FileDelete
GetFileAttributeValues	FileDirectory

In addition to the mapping to the application layer, Part 8.1 defines profiles for the “other” layers of the communication stack that are dependent on the service provided (as shown in figure 4 below). Of note on the various profiles: the Sampled

Values and GOOSE applications map directly into the Ethernet data frame thereby eliminating processing of any middle layers; the MMS Connection Oriented layer can operate over TCP/IP or ISO; the Generic Substation Status Event (GSSE) is the identical implementation as the UCA GOOSE and operates over connectionless ISO services; all data maps onto an Ethernet data frame using either the data type “Ethertype” in the case of Sampled Values, GOOSE, TimeSync, and TCP/IP or “802.3” data type for the ISO and GSSE messages.

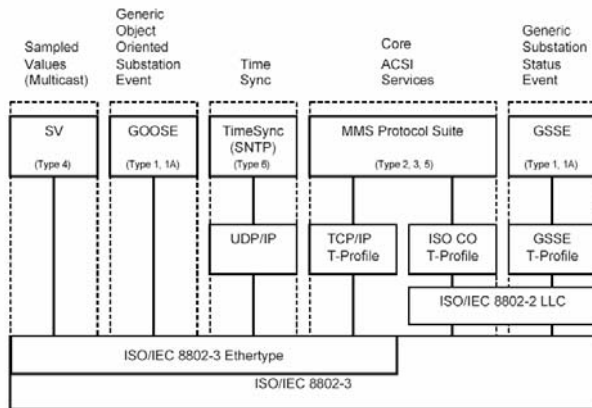

Fig. 4. Overview of IEC 61850 Functionality and Associated Communication Profiles

V. PROCESS BUS

As technology migrates to “next generation” low-energy voltage and current sensors, the ability to digitize the base quantities at the source and transmit the resulting sample values back to the substation becomes a need. In addition to Sampled Values, the ability to remotely acquire status information as well as set output controls is very desirable. IEC 61850 addresses this need through the definition of Sampled Measured Values services and the implementation of a Process Bus. The Process layer of the substation is related to gathering information, such as Voltage, Current, and status information, from the transformers and transducers connected to the primary power system process – the transmission of electricity. IEC 61850 defines the collection of this data via two different protocol definitions, namely, Part 9.1 which defines a Unidirectional Multidrop Point-to-Point fixed link carrying a fixed dataset and Part 9.2 which defines a “configurable” dataset that can be transmitted on a multi-cast basis from one publisher to multiple subscribers.

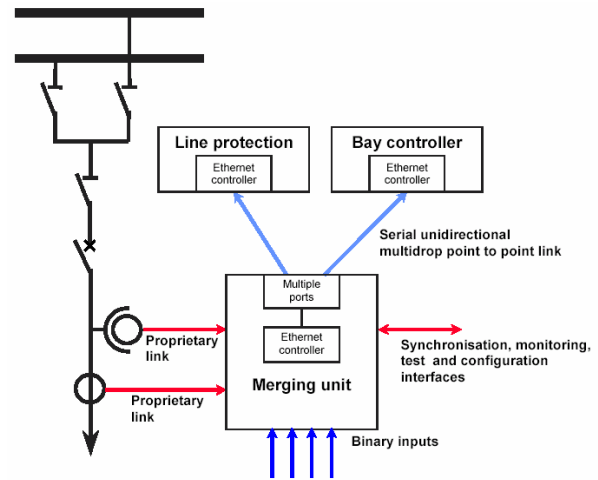

Fig. 5. Sample Measured Value Concept

Figure 5, above, shows the basic concept of the Process Bus. Signals from voltage and current sources (low or high energy) as well as status information are input into a “Merging Unit” (MU). The Merging Units in a station sample the signals at an agreed, synchronized rate. In this manner, any IED can input data from multiple MUs and automatically align and process the data. At this time, there is an implementation agreement that defines a base sample rate of 80 samples per power system cycle for basic protection and monitoring and a “high” rate of 256 samples per power system cycle for high-frequency applications such as power quality and high-resolution oscillography.

Part 9.1 specifies a pre-configured or “universal” dataset as defined in IEC60044-8. This dataset includes 3-phase voltage, bus voltage, neutral voltage, 3-phase currents for protection, 3-phase currents for measurement and two 16-bit status words. Note that the analog data values are mapped into 16 bit registers in this mapping.

Part 9.2 is a more generalized implementation of Sampled Measured Values (SMV) data transfer. In 9.2, the dataset or “payload” is user-defined using the SCL. As a dataset, data values of various sizes and types can be integrated together. Note that the existing implementation agreement proposed a data value size of 32 bits with a scale factor of 1 count = 1ma.

Both 9.1 and 9.2 specify mapping directly onto an Ethernet transport (see figure 4 above). Depending on the sample data rate, anywhere from 1 to 5 devices can be mapped onto a single 100MB Ethernet link. Multiple 100MB Ethernet data streams can then be combined into a single Ethernet switch with a 1GB backbone. In this configuration, 50 or more datasets can be published to multiple subscribers.

VI. SUBSTATION CONFIGURATION LANGUAGE

IEC 61850-6-1 specifies a Substation Configuration Language (SCL) that is based on the eXtensible Markup Language (XML) to describe the configuration of IEC 61850 based systems. SCL specifies a hierarchy of configuration files that enable multiple levels of the system to be described in unambiguous and standardized XML files. The various SCL files include system specification description (SSD), IED capability description (ICD), substation configuration description (SCD), and configured IED description (CID) files. All these files are constructed in the same methods and format but have different scopes depending on the need.

Even though an IEC 61850 client can extract an IED's configuration from the IED when it is connected to that IED over a network, there are several scenarios where the availability of a formal off-line description language can bring very large benefits to users outside of configuring IEC 61850 client applications. These benefits include:

- SCL enables off-line system development tools to generate the files needed for IED configuration automatically from the power system design significantly reducing the cost and effort of IED configuration by eliminating most, if not all, manual configuration tasks.
- SCL enables the sharing of IED configuration among users and suppliers to reduce or eliminate inconsistencies and misunderstandings in system configuration and system requirements. Users can provide their own SCL files to ensure that IEDs are delivered to them properly configured.
- SCL allows IEC 61850 applications to be configured off-line without requiring a network connection to the IED for client configuration.

SCL can be used as best fits each user's requirements. A user can decide to use CID files to provide help in IED configuration using its existing system design processes. Or SCL can be used to restructure the entire power system design process to eliminate manual configuration, eliminate manual data entry errors, reduce misunderstanding between system capabilities and requirements, enhance the interoperability of the end system, and greatly increase the productivity and effectiveness of power system engineers.

VII. IEC 61850 SUBSTATION MODEL

Putting the pieces together results in the substation architecture shown in figure 6.

At the "process" layer, data from Optical/Electronic Voltage and Current sensors as well as status information will be collected and digitized by the Merging Units (MUs). MUs could be physically located either in the field or in the control house. Data from the MUs will be collected through

redundant 100MB fiber optic Ethernet connections. The collection points will be redundant Ethernet switches with 1GB internal data buses and 1GB uplinks that support Ethernet priority and Ethernet Virtual LAN (VLAN). VLAN allows the

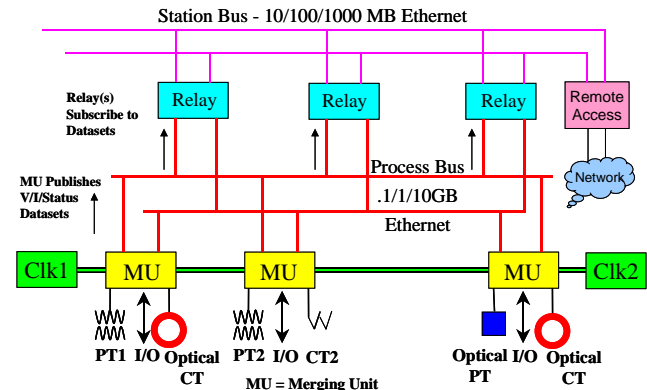

Fig. 6. IEC 61850 Substation Architecture

Ethernet switch to deliver datasets to only those switch ports/IEDs that have subscribed to the data. In migrating to Process Bus implementations, manufacturers will need to provide the ability to integrate data from existing CTs and PTs with the data from the newer Optical/Electronic sensors. A redundant synchronization clock architecture will also have to be addressed. In this architecture, upon detection of failure of Clock 1, Clock 2 will have to automatically come on line and continue providing sampling synchronization.

At the substation level, a Station Bus will exist. Again, this bus will be based today on 10MB Ethernet with a clear migration path to 100MB Ethernet. The Station Bus will provide primary communications between the various Logical Nodes, which provide the various station protection, control, monitoring, and logging functions. Communications will operate on either a connection oriented basis (e.g. – request of information, configuration, etc.) or a connection-less basis (IEC Generic Object Oriented Substation Event - GOOSE). Again, a redundant communication architecture is recommended as application of IED to IED data transmission puts the communication system on the critical path in case of a failure.

Finally, this architecture supports remote network access for all types of data reads and writes. As all communication is network enabled, multiple remote "clients" will desire access the wide variety of available information. Typical clients would include local HMI, operations, maintenance, engineering, and planning. The remote access point is one logical location to implement security functions such as encryption and authentication. This implementation unburdens the individual IEDs from performing encryption on internal data transfers but still provide security on all external transactions.

VIII. BENEFITS OF IEC 61850

One of the significant challenges that substation engineers face is justifying substation automation investments. The positive impacts that automation has on operating costs, increased power quality, and reduced outage response are well known. But little attention is paid to how the use of a communication standard impacts the cost to build and operate the substation. Legacy communication protocols were typically developed with the dual objective of providing the necessary functions required by electric power systems while minimizing the number of bytes that were used by the protocol because of severe bandwidth limitations that were typical of the serial link technology available 10-15 years ago when many of these protocols were initially developed. Later, as Ethernet and modern networking protocols like TCP/IP became widespread, these legacy protocols were adapted to run over TCP/IP-Ethernet. This approach provided the same basic electric power system capabilities as the serial link version while bringing the advantages of modern networking technologies to the substation. But this approach has a fundamental flaw: the protocols being used were still designed to minimize the bytes on the wire and do not take advantage of the vast increase in bandwidth that modern networking technologies deliver by providing a higher level of functionality that can significantly reduce the implementation and operational costs of substation automation.

IEC 61850 is unique. IEC 61850 is not a former serial link protocol recast onto TCP/IP-Ethernet. IEC 61850 was designed from the ground up to operate over modern networking technologies and delivers an unprecedented amount of functionality that is simply not available from legacy communications protocols. These unique characteristics of IEC 61850 have a direct and positive impact on the cost to design, build, install, commission, and operate power systems. While legacy protocols on Ethernet enable the substation engineer to do exactly the same thing that was done 10-15 years ago using Ethernet, IEC 61850 enables fundamental improvements in the substation automation process that is simply not possible with a legacy approach, with or without TCP/IP-Ethernet. To better understand the specific benefits we will first examine some of the key features and capabilities of IEC 61850 and then explain how these result in significant benefits that cannot be achieved with the legacy approach

A. Key Features

The features and characteristics of IEC 61850 that enable unique advantages are so numerous that they cannot practically be listed here. Some of these characteristics are seemingly small but yet can have a tremendous impact on substation automation systems. For instance, the use of VLANs and priority flags for GOOSE and SMV enable much more intelligent use of Ethernet switches that in and of itself can deliver significant benefits to users that aren't available

with other approaches. For the sake of brevity, we will list here some of the more key features that provide significant benefits to users:

- **Use of a Virtualized Model.** The virtualized model of logical devices, logical nodes, ACSI, and CDCs enables definition of the data, services, and behavior of devices to be defined in addition to the protocols that are used to define how the data is transmitted over the network.
- **Use of Names for All Data.** Every element of IEC 61850 data is named using descriptive strings to describe the data. Legacy protocols, on the other hand, tend to identify data by storage location and use index numbers, register numbers and the like to describe data.
- **All Object Names are Standardized and Defined in a Power System Context.** The names of the data in the IEC 61850 device are not dictated by the device vendor or configured by the user. All names are defined in the standard and provided in a power system context that enables the engineer to immediately identify the meaning of data without having to define mappings that relate index numbers and register numbers to power system data like voltage and current.
- **Devices are Self-Describing.** Client applications that communicate with IEC 61850 devices are able to download the description of all the data supported by the device from the device without any manual configuration of data objects or names.
- **High-Level Services.** ACSI supports a wide variety of services that far exceeds what is available in the typical legacy protocol. GOOSE, GSSE, SMV, and logs are just a few of the unique capabilities of IEC 61850.
- **Standardized Configuration Language.** SCL enables the configuration of a device and its role in the power system to be precisely defined using XML files.

B. Major Benefits

The features described above for IEC 61850 deliver substantial benefits to users that understand and take advantage of them. Rather than simply approaching an IEC 61850 based system in the same way as any other system, a user that understands and takes advantage of the unique capabilities will realize significant benefits that are not available using legacy approaches.

- **Eliminate Procurement Ambiguity.** Not only can SCL be used to configure devices and power systems, SCL can also be used to precisely define user requirement for substations and devices. Using SCL a user can specify exactly and unambiguously what is expected to be provided in each device that is not subject to misinterpretation by suppliers.

- **Lower Installation Cost.** IEC 61850 enables devices to quickly exchange data and status using GOOSE and GSSE over the station LAN without having to wire separate links for each relay. This significantly reduces wiring costs by more fully utilizing the station LAN bandwidth for these signals and construction costs by reducing the need for trenching, ducts, conduit, etc.
- **Lower Transducer Costs.** Rather than requiring separate transducers for each device needing a particular signal, a single merging unit supporting SMV can deliver these signals to many devices using a single transducer lowering transducer, wiring, calibration, and maintenance costs.
- **Lower Commissioning Costs.** The cost to configure and commission devices is drastically reduced because IEC 61850 devices don't require as much manual configuration as legacy devices. Client applications no longer need to be manually configured for each point they need to access because they can retrieve the points list directly from the device or import it via an SCL file. Many applications require nothing more than setting up a network address in order to establish communications. Most manual configuration is eliminated drastically reducing errors and rework.
- **Lower Equipment Migration Costs.** Because IEC 61850 defines more of the externally visible aspects of the devices besides just the encoding of data on the wire, the cost for equipment migrations is minimized. Behavioral differences from one brand of device to another is minimized and, in some cases, completely eliminated. All devices share the same naming conventions minimizing the reconfiguration of client applications when those devices are changed.
- **Lower Extension Costs.** Because IEC 61850 devices don't have to be configured to expose data, new extensions are easily added into the substation without having to reconfigure devices to expose data that was previously not accessed. Adding devices and applications into an existing IEC 61850 system can be done with only a minimal impact, if any, on any of the existing equipment.
- **Lower Integration Costs.** By utilizing the same networking technology that is being widely used across the utility enterprise the cost to integrate substation data into the enterprise is substantially reduced. Rather than installing costly RTUs that have to be manually configured and maintained for each point of data needed in control center and engineering office application, IEC 61850 networks are capable of delivering data without separate communications front-ends or reconfiguring devices.
- **Implement New Capabilities.** The advanced services and unique features of IEC 61850 enables new capabilities that are simply not possible with most legacy protocols. Wide area protection schemes that would normally be cost prohibitive become much more feasible. Because devices are already connected to the substation LAN, the incremental cost for accessing or sharing more device data becomes insignificant enabling new and innovative applications that would be too costly to produce otherwise.

IX. CONCLUSIONS

IEC 61850 is now released to the industry. Ten parts of the standard are now International Standards (part 10 is a draft international standard). This standard addresses most of the issues that migration to the digital world entails, especially, standardization of data names, creation of a comprehensive set of services, implementation over standard protocols and hardware, and definition of a process bus. Multi-vendor interoperability has been demonstrated and compliance certification processes are being established. Discussions are underway to utilize IEC 61850 as the substation to control center communication protocol. IEC 61850 will become the protocol of choice as utilities migrate to network solutions for the substations and beyond.

X. ACKNOWLEDGEMENTS

The author gratefully acknowledges the contributions of Mark Adamiak and Drew Baigent of GE Multilin for their work on the original version of this document presented at the SIPSEP conference in Monterrey, Mexico in 2004.

XI. ABOUT THE AUTHOR

Ralph Mackiewicz is Vice President of Business Development for SISCO, Inc. a Sterling Heights, Michigan developer of standards based real-time communications and integration products. SISCO was founded in 1983 and is the leading supplier of IEC 61850 technology to OEMs and end users world-wide. SISCO's mission is to provide standards-based real-time communications and integration solutions for the energy utility industry. Today, SISCO supplies technology incorporating IEC 61850, IEC 60870-6 TASE.2 (ICCP), the common information model (CIM) and the generic interface definition (GID) per IEC 61970, IEC 61968, and the OPC Foundation to hundreds of companies across the world.

