



## The CIP Advantage™ Technology Overview Series

# EtherNet/IP™ - CIP on Ethernet Technology

EtherNet/IP™ was introduced in 2001 and today is the most developed, proven and complete industrial Ethernet network solution available for manufacturing automation. EtherNet/IP is a member of a family of networks that implements the Common Industrial Protocol (CIP™) at its upper layers. CIP encompasses a comprehensive suite of messages and services for a variety of manufacturing automation applications, including control, safety, synchronization, motion, configuration and information. As a truly media-independent protocol that is supported by hundreds of vendors around the world, CIP provides users with a unified communication architecture throughout the manufacturing enterprise.

With media independence comes the ability to choose the CIP Network best suited for each application. One of these possible choices is EtherNet/IP, which adapts CIP to Ethernet Technology. Why adapt CIP to Ethernet? Ethernet - and the TCP/IP Suite to which it is inextricably linked, thanks to the ubiquitous adoption of Internet technology - is the same network technology used in the majority of local area network (LAN) and wide area network (WAN) architectures found in commercial and domestic applications around the world. These architectures connect computers to one another and to peripherals, link operations to the enterprise, or provide users with access to web-based applications. Ethernet has an installed base numbering in the billions of nodes. By leveraging the economies of scale in this proven commercial technology, EtherNet/IP provides users with the tools to deploy standard Ethernet technology for manufacturing applications while enabling Internet and enterprise connectivity for data anytime, anywhere.

EtherNet/IP offers several unique advantages for manufacturing automation applications:

- Complete producer-consumer services let you simultaneously control, configure and collect data from intelligent devices over a single network or use a single network as a backbone for multiple distributed CIP Networks
- Compatible with standard Internet protocols — e.g., HTTP, FTP, SNMP, and DHCP — and standard industrial protocols for data access and exchange such as OPC
- Compliance with IEEE Ethernet standards provides users with a choice of network interface speeds — e.g., 10, 100 Mbps and 1 Gbps — and a flexible network architecture compatible with commercially available Ethernet installation options including copper, fiber, fiber ring and wireless
- Options for industrially rated devices incorporating IP67-rated connectors (RJ45 or M12) with module and network status LEDs with device labeling for ease of use

Here's a more in-depth look at the technology behind every EtherNet/IP-compliant product.

## What is EtherNet/IP?

EtherNet/IP, like other CIP Networks, follows the Open Systems Interconnection (OSI) model, which defines a framework for implementing network protocols in seven layers: physical, data link, network, transport, session, presentation and application. Networks that follow this model define a complete suite of network functionality from the physical implementation through the application or user interface layer. As with all CIP Networks, EtherNet/IP implements CIP at the Session layer and above and adapts CIP to the specific EtherNet/IP technology at the Transport layer and below. This network architecture is shown in Figure 1.

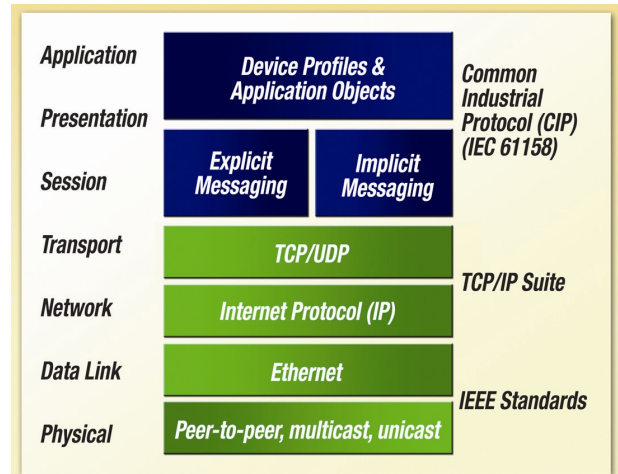

**Figure 1**  
**EtherNet/IP Adaptation of CIP**

Ethernet has the unique characteristic of being a network with an active infrastructure. Therefore, unlike typical device or control level networks—which generally have a passive infrastructure that limits the number of devices that can be connected and the way they can be connected—the EtherNet/IP network infrastructure can accommodate a virtually unlimited number of point-to-point nodes, providing users with unsurpassed flexibility in designing networks that accommodate their current requirements while enabling easy, cost-effective expansion in the future.

To further decrease complexity, EtherNet/IP systems require only a single point of connection for both configuration and control, because EtherNet/IP supports both I/O (or implicit) messages—those that typically contain time-critical control data—and explicit messages—those in which the data field carries both protocol information and instructions for service performance. And, as a producer-consumer network that supports multiple communication hierarchies and message prioritization, EtherNet/IP provides more efficient use of bandwidth than a device network based on a source-destination model. EtherNet/IP systems can be configured to operate either in a master/slave or distributed control architecture using peer-to-peer communication.

## The Physical Layer

EtherNet/IP uses standard IEEE 802.3 technology at the Physical and Data Link Layers. This standard provides a specification for physical media, defines a simple frame format for moving packets of data between devices and supplies a set of rules for determining how network devices respond when two devices attempt to use a data channel simultaneously. This is known as CSMA/CD (Carrier Sense Multiple Access/Collision Detection).

As a network with an active infrastructure, EtherNet/IP is typically configured using a series of network segments constructed of point-to-point connections in a star configuration. The core of this network topology is an interconnection of Ethernet Layer 2 and Layer 3 switches that, as previously mentioned, can accommodate an unlimited number of point-to-point nodes.

Most manufacturers offer pre-made or custom “patch” cables in a wide variety of lengths. Typically, a backbone of switches, in which each switch isolates a machine or a major part of a machine, is connected with 100Mbps-fiber optic cables. The other ports of the switch can be connected using twisted pair or fiber cables to the control devices for that part of the

machine or manufacturing process. At a higher level, EtherNet/IP networks can be either isolated (not connected directly to the enterprise network) or non-isolated, meaning the network is either connected to or integrated with the enterprise network.

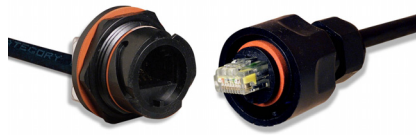

**Figure 2**  
**8-Way Modular Sealed Jack & Plug**  
**(plastic housing)**



**Figure 3**  
**8-Way Modular Sealed Jack & Plug**  
**(metal housing)**



**Figure 4**  
**M12-4 Connectors**

Based on performance requirements, users can specify either Industrial EtherNet/IP products that have implemented options for the physical layer to improve reliability in industrial applications—such as high-noise applications or those in which high-pressure washdown IP67 ratings are required—or COTS products. In addition, CAT 5E Ethernet cable is recommended for reliability in manufacturing applications, as this cable provides greater noise immunity and other safeguards against harsh industrial environments. Both copper (shielded or unshielded twisted pair) and fiber cabling options are available, as well as sealed or non-sealed RJ45 connectors for copper wires and SC, ST or MTRJ connectors for fiber optic cables.

### The Data Link Layer

IEEE’s 802.3 specification is also the standard used for transmitting packets of data from device to device on the EtherNet/IP Data Link Layer. Ethernet employs a CSMA/CD media access mechanism that determines how networked devices share a common bus (i.e., cable), and how they detect and respond to data collisions.

Originally, Ethernet worked in a half-duplex mode of operation, meaning that a node could send or receive data, but it could not do both at the same time. This caused data traffic jams, which are unacceptable in time-critical control applications. Now, with full-duplex Ethernet, networked devices can both send and receive packets of Ethernet data at the same time. This is one of several advances in Ethernet technology that has increased its level of determinism to the point where Ethernet can be used in an ever-increasing number of manufacturing applications.

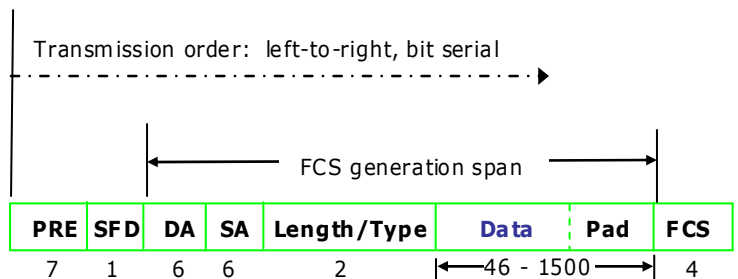

PRE=Preamble  
SFD=Start-of-Frame delimiter  
DA=Destination address  
SA=Source address

**Figure 5**  
**Anatomy of the Ethernet Frame**

The Media Access Control (MAC) protocol of the IEEE 802.3 specification is what actually allows devices to “talk” on the Ethernet network. Each device has a unique MAC address comprised of a 6-byte number that is regulated by IEEE and the product manufacturer to maintain uniqueness. This MAC address is used in the source address (SA) field of the frame to indicate what node sent the frame, and it is used

in the destination address (DA) field to indicate the destination of the frame. Setting the first bit to a "1" in the DA field indicates a packet of data for multiple destinations, and enables an Ethernet node to transmit a single data packet to broadcast to the various destinations.

A single frame of industrial EtherNet/IP can contain up to 1,500 bytes of data, depending on the application requirements. The combination of real-time control with high-data capacity makes industrial Ethernet increasingly attractive, as more intelligence is embedded into smaller and less-expensive devices.

### The Network and Transport Layers

At the Network and Transport Layers, EtherNet/IP utilizes the Internet standard known as the Transmission Control Protocol/Internet Protocol (TCP/IP) Suite to send messages between one or more devices. TCP/IP provides the necessary communication protocol features needed to implement fully functional networks (i.e., an addressing scheme and mechanisms for establishing a connection with a device and exchanging data) that the IEEE specification in and of itself lacks.

Also, at these layers, the standard CIP messages used by all CIP Networks are encapsulated. TCP/IP encapsulation allows a node on the network to embed a message as the data portion in an Ethernet message. The node then sends the message—TCP/IP protocol with the message inside—to an Ethernet communication chip (the Data Link Layer). By using TCP/IP, EtherNet/IP is able to send explicit messages, which are used to perform client-server type transactions between nodes.

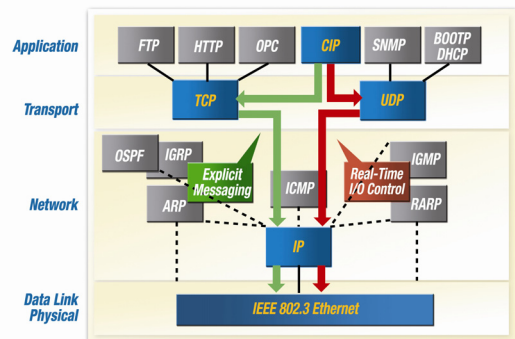

**Figure 6**  
**CIP: Fully compatible with widely used Ethernet and Internet protocols**

The TCP/IP Suite consists of the following:

- The **TCP** portion of the TCP/IP protocol is a connection-oriented, uni-cast transport mechanism that provides data flow control, fragmentation reassembly and message acknowledgements. Nodes must interpret each message, execute the requested task and generate responses. Since TCP is ideal for the reliable transmission of large quantities of data, EtherNet/IP uses TCP/IP to encapsulate CIP explicit messages, which are generally used to transmit configuration, diagnostic and event data.
- The **IP** portion of the TCP/IP protocol is the mechanism that enables packet routing through multiple possible paths. The ability to send messages to their destinations even when the primary path is disrupted is the basis of the Internet. This same type of routing is used in industrial networks to maintain proper separation of control elements and other factory infrastructure through the use of managed switches and Layer 3 routers. All devices and infrastructure components with added diagnostic capabilities (managed switches and routers) on an industrial Ethernet-based system must be assigned an IP address. This is most commonly identified by the four-byte address listed in the "network properties" on personal computers that use TCP/IP as their Ethernet network connection (e.g., 192.137.1.11). IP addresses must be unique on a given network.

For real-time messaging, EtherNet/IP also employs **UDP over IP**, which allows messages to be multicast to a group of destination addresses. This is how CIP I/O data transfers (implicit messaging) are sent on EtherNet/IP. With implicit messaging, the data field contains no protocol information, only real-time I/O data. Since the meaning of the data is pre-defined at the time the connection is established, processing time is minimized during runtime. UDP is connectionless and makes no guarantee that data will get from one device to another; however, UDP messages are smaller and can be processed more quickly than explicit messages. As a result, EtherNet/IP uses UDP/IP to transport I/O messages that typically contain time-critical control data. The CIP Connection mechanism provides timeout mechanisms that can detect data delivery problems, a capability that is essential for reliable control system performance.

EtherNet/IP uses two forms of messaging:

- **Unconnected messaging** is used in the connection establishment process and for infrequent, low-priority messages. The unconnected resources in a device are referred to as the Unconnected Message Manager, or UCMM. Unconnected messages on EtherNet/IP utilize TCP/IP resources to move messages across Ethernet. To receive ODVA's Declaration of Conformity, EtherNet/IP products are required to implement a UCMM to receive requests from other devices.
- **Connected messaging** on EtherNet/IP utilizes resources within each node that are dedicated in advance to a particular purpose, such as frequent explicit message transactions or real-time I/O data transfers. Connection resources are reserved and configured using communications services available via the UCMM.

The process of opening a connection is called Connection Origination, and the node that initiates the connection establishment request is called a Connection Originator, or just an Originator. Conversely, the node that responds to the establishment request is called a Connection Target, or a Target.

EtherNet/IP has two types of messaging connections:

- **Explicit messaging connections** are point-to-point relationships that are established to facilitate request-response transactions between two nodes. These connections are general purpose in nature and can be used to reach any network-accessible items within a device. Explicit messaging connections utilize TCP/IP services to move messages across Ethernet.
- **Implicit (I/O data) connections** are established to move application-specific I/O data at regular intervals. These connections often are set up as one-to-many relationships in order to take full advantage of the producer-consumer multicast model. Implicit messaging uses UDP/IP resources to make multicast data transfers over Ethernet a reality.

EtherNet/IP supports three device classes based on network communication capabilities: Messaging Class, Adapter Class and Scanner Class. Each class supports a basic set of communications services, but may provide other optional services too.

**Messaging Class** products support explicit messaging (connected or unconnected) that is sent or received from all other classes of products. Messaging Class products are the targets of explicit message connection requests, and may also be originators of these requests, but they cannot send or receive real-time I/O data.

Examples of products in this class include:

- Computer interface cards used for program upload and download to HMI products, robots and PLCs;
- Computer interface cards or other hardware that supports HMI applications that gather data from control systems (i.e., MIS);
- Software applications that do not require real-time I/O response; and
- Network configuration and diagnostic tools.

**Adapter Class** products are the targets of real-time I/O data connection requests from Scanner Class products. They cannot send or receive real-time I/O data unless they are requested to do so by a scanner, and they do not store or originate the data communications parameters necessary to establish the connection. Adapter Class products receive explicit message requests (connected or unconnected) from all other classes of products. They may also exchange (peer) data using explicit messages with any class of device, but they cannot originate such relationships.

Examples of products in this class include:

- I/O rack adapters that produce and consume real-time I/O data;
- Weigh scales, welders, drives and robots that send and receive real-time data at the request of PLCs and other controllers;
- Weigh scales, welders, drives and robots that send and receive explicit messages to and from computer interface cards, PLCs and each other; and
- HMI products that send or receive explicit or real-time I/O data to/from PLCs.

**Scanner Class** products are the originators of I/O data connection requests to Adapter Class products, as well as to other Scanner Class products (i.e., peer-to-peer explicit or I/O data). These products may also be the originators or targets of explicit connection requests to and from other classes of products, and they can also send or receive explicit messages to or from all other classes of products.

Examples of products in this class include:

- PLCs, controllers and robots that send and receive real time data to I/O rack adapters, PLCs, robots, weigh scales, welders and MMI products;
- PLCs, controllers and robots that send and receive explicit message data to other PLCs, robots, weigh scales, computer cards, welders and MMI products; and
- Computer interface cards used for PC-based control.

## The Upper Layers

EtherNet/IP uses the Common Industrial Protocol (CIP), a strictly object-oriented protocol, at the upper layers. Each CIP object has attributes (data), services (commands) and behaviors (reactions to events). CIP's producer-consumer communication model provides more efficient use of network resources than a source-destination model by allowing the exchange of application information between a sending device (e.g., the producer) and many receiving devices (e.g., the consumers) without requiring data to be transmitted multiple times by a single source to multiple destinations. In producer-consumer networks, a message is identified by its connection ID, not its destination address (as is the case with source-destination networks). CIP's message structure makes it possible for multiple nodes to consume data produced by a single source based solely on the connection ID to which the message refers. Thus, the producer-consumer model provides a clear advantage for users of CIP Networks by making efficient use of network resources in the following ways:

- If a node wants to receive data, it only needs to ask for it once to consume the data each time it is produced.
- If a second (third, fourth, etc.) node wants the same data, all it needs to know is the connection ID to receive the same data simultaneously with all other nodes.

CIP also includes "device types" for which there are "device profiles." For a given device type, the device profile will specify the set of CIP objects that must be implemented, configuration options and I/O data formats. This consistency in object implementation for a given device type provides another clear advantage for users of CIP Networks by promoting a common application interface for a given device type and interoperability in networks comprised of devices from multiple vendors. For applications where unique functionality is required, it is also possible for an EtherNet/IP vendor to define additional vendor-specific objects in an EtherNet/IP-compliant product in order to support the functional requirements of particular applications.

Seamless bridging and routing is perhaps the most significant advantage for users of CIP Networks for it is this mechanism that most protects the user's investment for the future. The ability to originate a message on one CIP Network, such as DeviceNet, and then pass it to another CIP Network, such as EtherNet/IP, with no presentation at the Application Layer, means that users can incorporate incremental application improvements to existing installations and/or integrate automation systems with diagnostic, prognostic and/or IT applications. Seamless bridging and routing between both homogeneous and heterogeneous CIP Networks is enabled by a set of objects that defines routing mechanisms for a device to use when forwarding the contents of a message produced on one network port to another. This mechanism does not alter the contents of a message during the routing process. When using this mechanism, the user's only responsibility is to describe the path that a given message must follow. CIP ensures that the message is handled correctly, independent of the CIP Networks involved.

### **Management of the EtherNet/IP Technology**

EtherNet/IP is managed jointly by ODVA, an international association of the world's leading automation companies, and ControlNet International. ODVA's EtherNet/IP management responsibilities include:

- Publishing the EtherNet/IP Specification;
- Overseeing the process to incorporate new enhancements to the EtherNet/IP Specification;
- Licensing the EtherNet/IP Technology to companies desiring to make and/or sell EtherNet/IP-compliant products;
- Promoting industry awareness of EtherNet/IP and its benefits; and
- Helping to ensure compliance of EtherNet/IP products with the specification through conformance testing and conformity reporting.

For more information about EtherNet/IP, CIP or ODVA, visit ODVA on the World Wide Web at **[www.odva.org](http://www.odva.org)**.

## **About ODVA**

ODVA is an international association comprised of members from the world's leading automation companies. Collectively, ODVA and its members support network technologies based on the Common Industrial Protocol (CIP™). These currently include DeviceNet™, EtherNet/IP™, CompoNet™, CIP Motion™, CIP Safety™ and CIP Sync™. ODVA manages the development of these open technologies, and assists manufacturers and users of CIP Networks through tools, training and marketing activities.

In addition, ODVA offers conformance testing to help ensure that products built to its specifications operate in multi-vendor systems. ODVA also is active in other standards development organizations and industry consortia to drive the growth of open communication standards.

*DeviceNet, CompoNet, DeviceNet Safety, EtherNet/IP Safety, CIP, CIP Motion, CIP Safety and CIP Sync are trademarks of Open DeviceNet Vendor Association, Inc. (ODVA). EtherNet/IP is a trademark of ControlNet International under license by ODVA. ControlNet is a trademark of ControlNet International. Other trademarks are property of their respective owners.*

## **ODVA**

Ann Arbor, Michigan, USA  
TEL: +1 734-975-8840  
FAX: +1 734-922-0027  
EMAIL: [odva@odva.org](mailto:odva@odva.org)  
WEB: [www.odva.org](http://www.odva.org)

PUB000138R2  
©2006 ODVA, Inc.